

(12) **EUROPEAN PATENT APPLICATION**
 published in accordance with Art. 158(3) EPC

(43) Date of publication: **05.02.2003 Bulletin 2003/06**
 (51) Int Cl.7: **G01N 27/327**
 (21) Application number: **02718528.9**
 (86) International application number: **PCT/JP02/03600**
 (22) Date of filing: **11.04.2002**
 (87) International publication number: **WO 02/086483 (31.10.2002 Gazette 2002/44)**

<p>(84) Designated Contracting States: AT BE CH CY DE DK ES FI FR GB GR IE IT LI LU MC NL PT SE TR</p> <p>(30) Priority: 16.04.2001 JP 2001116580</p> <p>(71) Applicant: MATSUSHITA ELECTRIC INDUSTRIAL CO., LTD. Kadoma-shi, Osaka 571-8501 (JP)</p> <p>(72) Inventors: <ul style="list-style-type: none"> TOKUNAGA, Hiroyuki Onsen-gun, Ehime 791-0212 (JP) </p>	<ul style="list-style-type: none"> MIYAZAKI, Shoji Matsuyama-shi, Ehime 791-8032 (JP) YAMANISHI, Eriko Onsen-gun, Ehime 791-0303 (JP) <p>(74) Representative: Grünecker, Kinkeldey, Stockmair & Schwanhäusser Anwaltssozietät Maximilianstrasse 58 80538 München (DE)</p>
---	--

(54) **BIOSENSOR**

(57) In a biosensor that detects introduction of a sample liquid into a specimen supply path using a detecting electrode, a means of improving accuracy of detection is provided. The biosensor has: an electrode system including measuring electrode (2), counter electrode (3), and detecting electrode (4) on first electrically insulating support (1); specimen supply path (7) for introducing the sample liquid; and reagent layer (5) used for quantifying a substrate contained in the sample liquid. The means is characterized in that detecting electrode (4) is spaced from measuring electrode (2) by a distance sufficient for the sample liquid to sufficiently cover measuring electrode (2) before the sample liquid reaches detecting electrode (4).

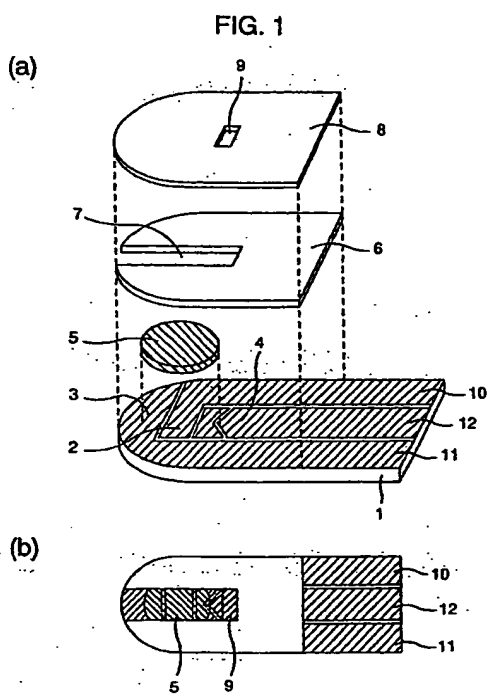

EP 1 281 955 A1

Description

TECHNICAL FIELD

[0001] The present invention relates to a biosensor that quantifies a substrate contained in a sample liquid.

BACKGROUND ART

[0002] A biosensor is a sensor that utilizes the molecule-identifying function of a biological material, e.g. a microorganism, enzyme, antibody, DNA, and RNA, and applies such a biological material as a molecule-identifying element. In other words, the biosensor utilizes the reaction occurring when an immobilized biological material identifies a target substrate, oxygen consumed by breathing of microorganism, enzyme reaction, luminescence, and the like. Among biosensors, practical use of enzyme sensors is developing. For example, enzyme sensors for glucose, lactic acid, uric acid, and amino acid find applications in medical instrumentation and food processing industry.

[0003] In an enzyme sensor, for example, electrons generated by the reaction of a substrate contained in a sample liquid, i.e. an analyte, with an enzyme or the like reduce an electron acceptor and a measuring device electrochemically measures the amount of the reduced electron acceptor. Thus, quantitative analysis of the analyte is performed. An example of such a biosensor is a sensor proposed in Patent Application No. PCT/JP00/08012.

[0004] In this biosensor, as shown in Fig. 4, electrically insulating support 1 made of polyethylene terephthalate or other materials has measuring electrode 2 (also referred to as a "working electrode"), counter electrode 3, and detecting electrode 4 that are made of electrically conductive materials and formed in proximity to one another on the electrically insulating support. Formed on these electrodes is reagent layer 5 that contains an enzyme specifically reacting with a particular component in the sample liquid, an electron transfer agent, a hydrophilic polymer, and the like.

[0005] Laminated thereon and bonded thereto are spacer 6 having a cutout for forming specimen supply path 7, and cover 8 (second electrically insulating support) having air hole 9. One end of the cutout in spacer 6 is in communication with air hole 9 provided through cover 8.

[0006] Described hereinafter is a system of checking for suction of an analyte when the content of a substrate in a sample liquid, i.e. the analyte, is determined using a conventional biosensor of such a structure.

[0007] First, a sample liquid is supplied to the inlet of specimen supply path 7 while a constant voltage is applied between counter electrode 3 or measuring electrode 2 and detecting electrode 4 by a measuring device (not shown) coupled to the biosensor. The sample liquid is sucked into specimen supply path 7 by capillarity,

passes over counter electrode 3 and measuring electrode 2, and reaches detecting electrode 4. Then, dissolution of reagent layer 5 starts. At this time, the measuring device detects electrical changes occurring between counter electrode 3 or measuring electrode 2 and detecting electrode 4 and starts measuring operation.

[0008] However, such a biosensor has a problem. Counter electrode 3, measuring electrode 2, and detecting electrode 4 are disposed in proximity to one another. Thus, when an amount of sample liquid insufficient to fill specimen supply path 7 is supplied as shown in Figs. 5 and 6, for example, the sample liquid reaches detecting electrode 4 without completely covering measuring electrode 2 and then the measuring operation starts. This makes the response value lower than that given when the specimen supply path is sufficiently filled with the sample liquid as shown in Fig. 7, thus deteriorating the performance of the biosensor. In the top views of Figs. 5 through 7, reagent layer 5 is not shown for simplicity.

[0009] The present invention aims to address the above-mentioned problem. Therefore, it is an object of the present invention to improve accuracy of detecting the analyte by adding new ideas on the position and shape of the detecting electrode and to provide a high-performance biosensor having excellent accuracy of measurement.

DISCLOSURE OF INVENTION

[0010] In order to address the above-mentioned problem, according to one aspect of the present invention, there is provided a biosensor including:

a first electrically insulating support and a second electrically insulating support;
an electrode system having at least a measuring electrode, a counter electrode, and a detecting electrode;

a specimen supply path for introducing the sample liquid over the electrode system; and
a reagent used for quantifying a substrate contained in the sample liquid. The biosensor is characterized in that the electrode system, the specimen supply path and the reagent exist between the first electrically insulating support and the second electrically insulating support. The electrode system is formed on all or part of the inner surface of at least one of the first electrically insulating support and the second electrically insulating support. The detecting electrode is spaced from the measuring electrode by a distance sufficient for the sample liquid to sufficiently cover the measuring electrode before the sample liquid reaches the detecting electrode.

[0011] The detecting electrode of this biosensor can be shaped to project so that the central portion of the

detecting electrode is positioned nearest to the measuring electrode within the specimen supply path. Moreover, the detecting electrode can be shaped so that the both edges thereof are positioned farther from the measuring electrode than the central portion.

[0012] The detecting electrode can also be shaped to project in the direction of the inlet of the specimen supply path in the central position of the specimen supply path.

[0013] These shapes of the detecting electrode positioned within the specimen supply path can be of V-shape, U-shape, or convex shape.

BRIEF DESCRIPTION OF DRAWINGS

[0014]

Fig. 1 is an exploded perspective view and a top view of a biosensor in accordance with an exemplary embodiment of the present invention.

Fig. 2 is an exploded perspective view and a top view showing an example of another biosensor in accordance with an exemplary embodiment of the present invention.

Fig. 3 is an exploded perspective view and a top view showing an example in accordance with an exemplary embodiment of the present invention that has an air hole disposed within a specimen supply path.

Fig. 4 is an exploded perspective view and a top view of a conventional biosensor.

Fig. 5 is a drawing showing how a sample liquid is introduced into a specimen supply path.

Fig. 6 is a drawing showing how a sample liquid is introduced into a specimen supply path.

Fig. 7 is a drawing showing how a sample liquid is sufficiently introduced into a specimen supply path.

BEST MODE FOR CARRYING OUT OF THE INVENTION

[0015] A biosensor in accordance with an exemplary embodiment of the present invention is demonstrated hereinafter with reference to Fig. 1. Specifically described herein is an enzyme sensor using an enzyme as a molecule-identifying element that specifically reacts with a particular component in a sample liquid.

[0016] Fig. 1 is an exploded perspective view and a top view of a biosensor in accordance with this embodiment. In Fig. 1, reference numeral 1 shows a first electrically insulating support. Formed on this first electrically insulating support 1 are measuring electrode 2, counter electrode 3, and detecting electrode 4 that are made of electrically conductive materials.

[0017] In this embodiment, what largely differs from a conventional biosensor is that detecting electrode 4 having a predetermined shape is spaced from counter electrode 3 and measuring electrode 2 by a predetermined distance in specimen supply path 7.

[0018] This predetermined distance means a distance sufficient for the sample liquid to completely cover measuring electrode 2 after the sample liquid is fed into specimen supply path 7 before reaching detecting electrode 4. This distance can be set arbitrarily according to the width of the specimen supply path.

[0019] As for the predetermined shape, it is desirable that detecting electrode 4 is shaped to lie nearest to the measuring electrode 2 in the central portion of specimen supply path 7 and farther to the measuring electrode along the both edges of specimen supply path 7 than in the central portion thereof. These shapes include a V-shape, U-shape, and convex shape, and combinations thereof. Among these shapes, a V-shape is most preferable.

[0020] Because the detecting electrode has such a distance and shape, measurement of a sample liquid starts after the liquid has completely covered the measuring electrode. When an amount of sample liquid insufficient to completely cover measuring electrode 2 is supplied as shown in Figs. 5 and 6, erroneous start of measurement can be prevented. Moreover, for the above-mentioned shape of detecting electrode 4, the detecting electrode can be disposed nearer to the measuring electrode. Therefore, the amount of sample liquid necessary for the biosensor to measure can be reduced.

[0021] In the biosensor of Fig. 1, the space between measuring electrode 2 and detecting electrode 4 does not work as an electrode. However, as shown in Fig. 2, the space can be utilized as a part of counter electrode 3.

[0022] Moreover, detecting electrode 4 described herein can be used as a part of the counter electrode, as well as working as an electrode for detecting an insufficient amount of analyte.

[0023] In the biosensor of Fig. 1, each of the electrodes is disposed on the first electrically insulating support. However, these electrodes can be divided and disposed not only on first electrically insulating support 1 but also on second electrically insulating support 8 opposed thereto.

[0024] Preferable materials of above-mentioned first electrically insulating support 1 and second electrically insulating support 8 include polyethylene terephthalate, polycarbonate, polyimide, and the like.

[0025] Electrically conductive materials constituting each electrode include single materials, such as noble metals (e.g. gold, platinum, and palladium) and carbon, and composite materials, such as carbon pastes and noble metal pastes.

[0026] The electrically conductive layer can be formed on first electrically insulating support 1 or second electrically insulating support 8 easily by such a method as sputtering vapor deposition for the single materials, and by such a method as screen-printing for the composite materials.

[0027] Each of the electrodes can be formed separately by forming the electrically conductive layer on all

or part of the surface of first electrically insulating support 1 or second electrically insulating support 8 by the above-mentioned sputtering vapor deposition and screen-printing and other methods, and subsequently providing slits therein using laser and other means. Similarly, the electrodes can be formed by screen-printing using a printing plate or mask having electrode patterns formed thereon in advance, sputtering vapor deposition, and other methods.

[0028] Formed on the electrodes formed in this manner is reagent layer 5 containing an enzyme, electron transfer agent, hydrophilic polymer, and the like.

[0029] Examples of the usable enzyme include glucose oxidase, lactate oxidase, cholesterol oxidase, cholesterol esterase, uricase, ascorbate oxidase, bilirubin oxidase, glucose dehydrogenase, and lactate dehydrogenase. Examples of the usable electron transfer agent include p-benzoquinone and derivatives thereof, phenazine methosulfate, methylene blue, and ferrocene and derivatives thereof as well as potassium ferricyanide.

[0030] Examples of the usable hydrophilic polymer include carboxymethyl cellulose, hydroxyethyl cellulose, hydroxypropyl cellulose, methyl cellulose, ethyl cellulose, ethyl hydroxyethyl cellulose, carboxymethyl ethyl cellulose, polyvinyl alcohol, polyvinyl pyrrolidone, polyamino acids (e.g. polylysine), polystyrene sulfonate, gelatin and derivatives thereof, acrylic acids and salts thereof, methacrylic acids and salts thereof, starch and derivatives thereof, maleic anhydrides and salts thereof, and agarose gel and derivatives thereof.

[0031] Next, the first electrically insulating support 1 and second electrically insulating support 8 are bonded to spacer 6 having a cutout to form specimen supply path 7 for receiving a sample liquid.

[0032] In order to reduce the amount of the sample liquid necessary for the biosensor to measure, it is desirable that specimen supply path 7 has a width ranging from 0.5 to 2.0 mm and spacer 6 has a thickness (height) ranging from 0.05 to 0.3 mm.

[0033] Examples of the preferable material of spacer 6 include polyethylene terephthalate, polycarbonate, polyimide, polybutylene terephthalate, polyamide, polyvinyl chloride, polyvinylidene chloride, polyimide, and nylon.

[0034] Alternatively, integrated second electrically insulating support 8 and spacer 6 can be bonded to first electrically insulating support 1 to form specimen supply path 7.

[0035] The reagent layer 5 can be placed in any position within specimen supply path 7 for receiving the sample liquid as well as on all or part of the surface of the electrodes, on condition that the reagent layer will not deteriorate the performance of the biosensor.

[0036] However, in order to realize quick detection of the sample liquid after the supply thereof, it is desirable that reagent layer 5 exists on detecting electrode 4 or in the vicinity thereof.

[0037] The supply of a sample liquid to a biosensor

structured of such specimen supply path 7 is realized by capillarity. In order to realize smooth supply of the sample liquid, air hole 9 for letting the air escape outside of the biosensor must be provided within specimen supply path 7.

[0038] Air hole 9 can be disposed in any position within specimen supply path 7 on condition that the air hole will not hinder the supply of the sample liquid. Air hole 9 can be of any size that can let the air escape smoothly.

When a small air hole is disposed within a specimen supply path, the sample liquid is easily be lead along the edges of the specimen supply path. Thus, the shape of the detecting electrode shown in Fig. 3 is most preferable.

[0039] In the biosensor of Fig. 3, arc slits are formed around the reagent dropping position. Specifically, by providing a wave-like arc slit 14 on the tip side of the sensor and slit 15 on the back side of the specimen supply path, propagation of the reagent is easily controlled in formation of reagent layer 5. These arc slits are more effective in controlling the reagent than the arc slit disclosed in the above-mentioned PCT patent application.

[0040] In addition, rendering hydrophilic nature to the inner surface of the specimen supply path 7 allows quicker and more accurate introduction of the sample liquid into specimen supply path 7.

[0041] The methods of rendering hydrophilic nature include applying surface-active agent to first electrically insulating support 1 or second electrically insulating support 8 itself, or the surface thereof, and roughening the surface of the support material by sandblasting, electric-discharge machining, non-glare treatment, matting, chemical plating, or the like.

[0042] Described hereinafter is a system of checking for suction of an analyte when the content of a substrate in a sample liquid, i.e. the analyte, is determined using a biosensor of such a structure.

[0043] First, a sample liquid is fed to the inlet of the specimen supply path while a constant voltage is applied between the counter electrode or the measuring electrode and the detecting electrode by a measuring device (not shown) coupled to the biosensor. The sample liquid is sucked into the specimen supply path by capillarity, passes over the counter electrode and the measuring electrode, and reaches the detecting electrode. Then, dissolution of the reagent layer starts. At this time, the measuring device detects electrical changes occurring between the counter electrode or the measuring electrode and the detecting electrode and starts measuring operation.

[0044] In this embodiment, an enzyme sensor is described as an example of a biosensor. However, the present invention can similarly be applied to a biosensor that uses an antibody, microorganism, DNA, RNA, or the like as well as the enzyme as a molecule-identifying element specifically reacting with a particular component in the sample liquid.

INDUSTRIAL APPLICABILITY

[0045] As mentioned above, the present invention can drastically improve the accuracy of detecting the introduction of a sample liquid into a specimen supply path using a detecting electrode. The present invention can also provide a high-performance biosensor causing less error of measurement. Furthermore, the sample liquid necessary for the biosensor to measure can be reduced. These advantages can provide a biosensor that has high user operability and can deal with a small amount of analyte.

Claims

1. A biosensor for quantifying a substrate contained in a sample liquid comprising:

a first electrically insulating support and a second electrically insulating support;
 an electrode system having at least a measuring electrode, a counter electrode, and a detecting electrode;
 a specimen supply path for introducing the sample liquid over said electrode system; and
 a reagent used for quantifying the substrate contained in the sample liquid;

wherein said electrode system, said specimen supply path, and said reagent exist between said first electrically insulating support and said second electrically insulating support;

wherein said electrode system is formed on one of all and part of an inner surface of at least one of said first electrically insulating support and said second electrically insulating support; and

wherein said detecting electrode is spaced from said measuring electrode by a distance sufficient for the sample liquid to sufficiently cover said measuring electrode before the sample liquid reaches said detecting electrode.

2. The biosensor as set forth in Claim 1, wherein said detecting electrode is shaped to project so that a central portion thereof is positioned nearest to said measuring electrode in said specimen supply path.
3. The biosensor as set forth in Claim 1, wherein said detecting electrode is shaped so that a central portion thereof is positioned nearest to said measuring electrode and both edges thereof are positioned farther to said measuring electrode than the central portion in said specimen supply path.
4. The biosensor as set forth in Claim 1, wherein said detecting electrode is shaped to project in a direction of an inlet of said specimen supply path in a

central position within said specimen supply path.

5. The biosensor as set forth in any one of Claims 2 through 4, wherein said detecting electrode positioned within said specimen supply path has one of a V-shape, a U-shape, and a convex shape.
6. The biosensor as set forth in any one of Claims 1 through 5, wherein said specimen supply path has a width ranging from 0.5 to 2.0 mm.
7. The biosensor as set forth in any one of Claims 1 through 6, wherein said specimen supply path has a height ranging from 0.05 to 0.3 mm.
8. The biosensor as set forth in any one of Claims 1 through 7, wherein said electrode system is divided by providing a slit in an electrically conductive layer formed on one of all and part of an inner surface of at least one of said first electrically insulating support and said second electrically insulating support.
9. The biosensor as set forth in Claim 8, wherein said slit is formed by machining the electrically conductive layer using laser.
10. The biosensor as set forth in any one of Claims 1 through 9, wherein an air hole in communication with said specimen supply path is formed.

FIG. 1

(a)

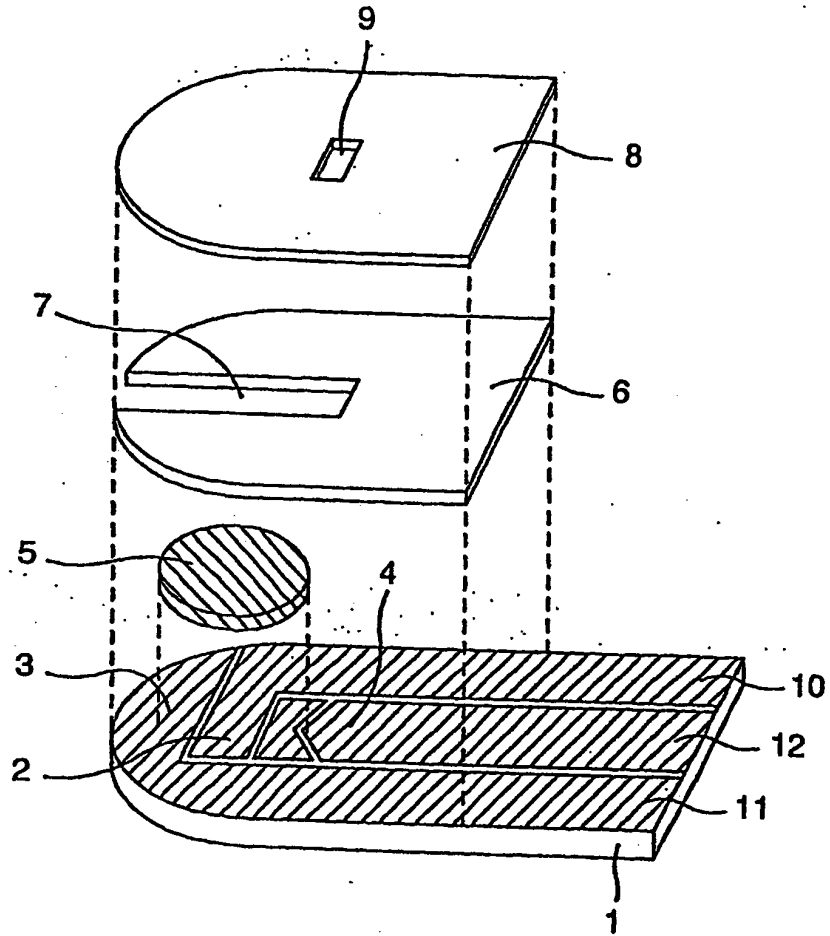

(b)

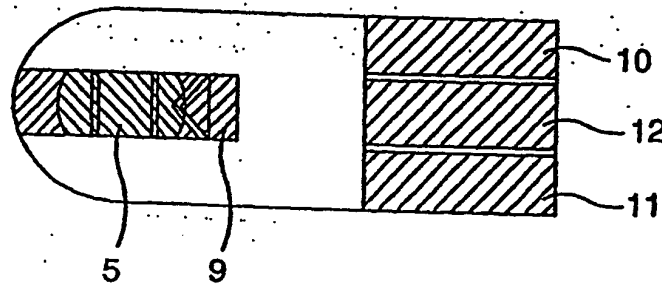
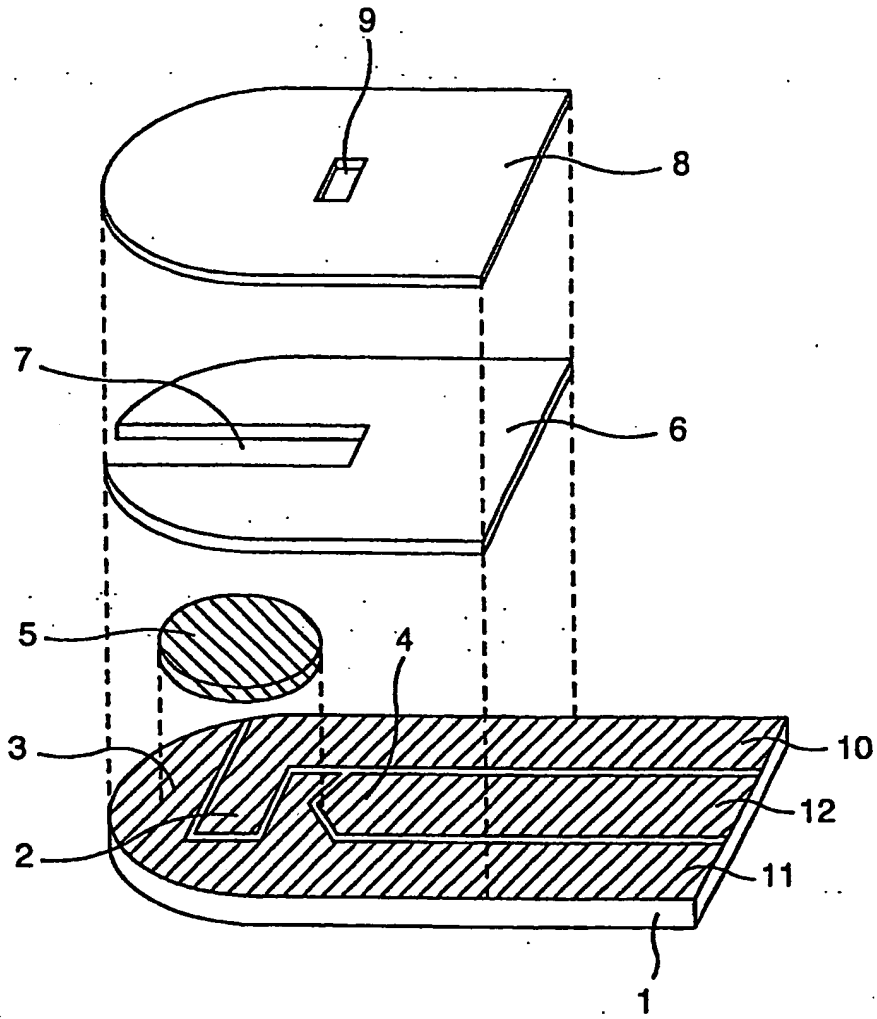

FIG. 2

(a)



(b)

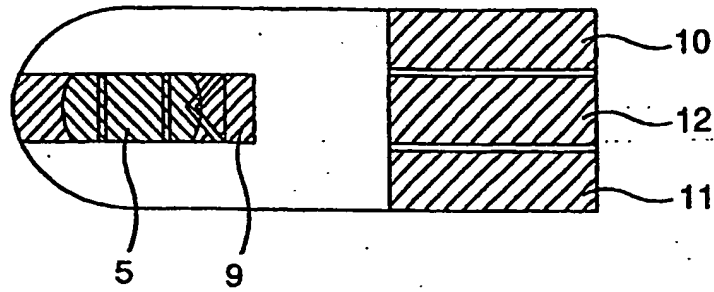
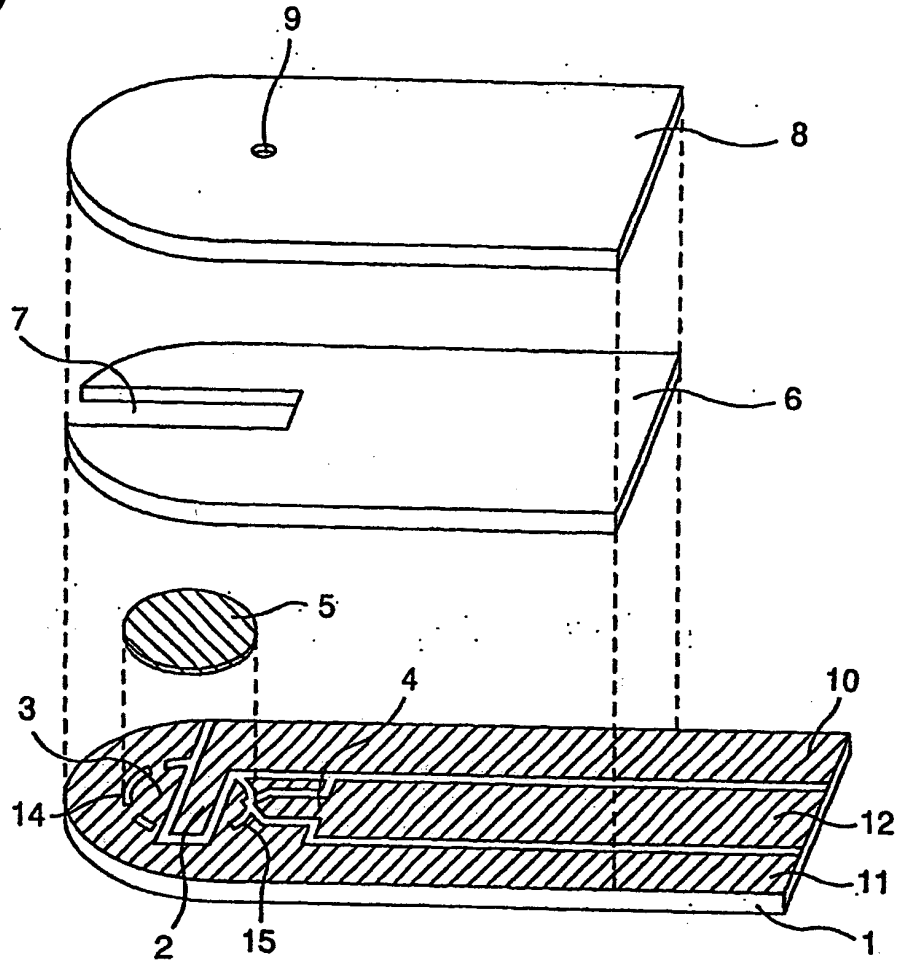

FIG. 3

(a)



(b)

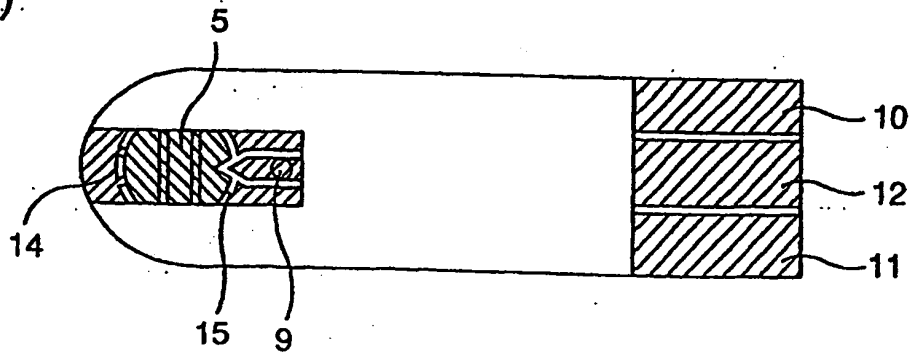
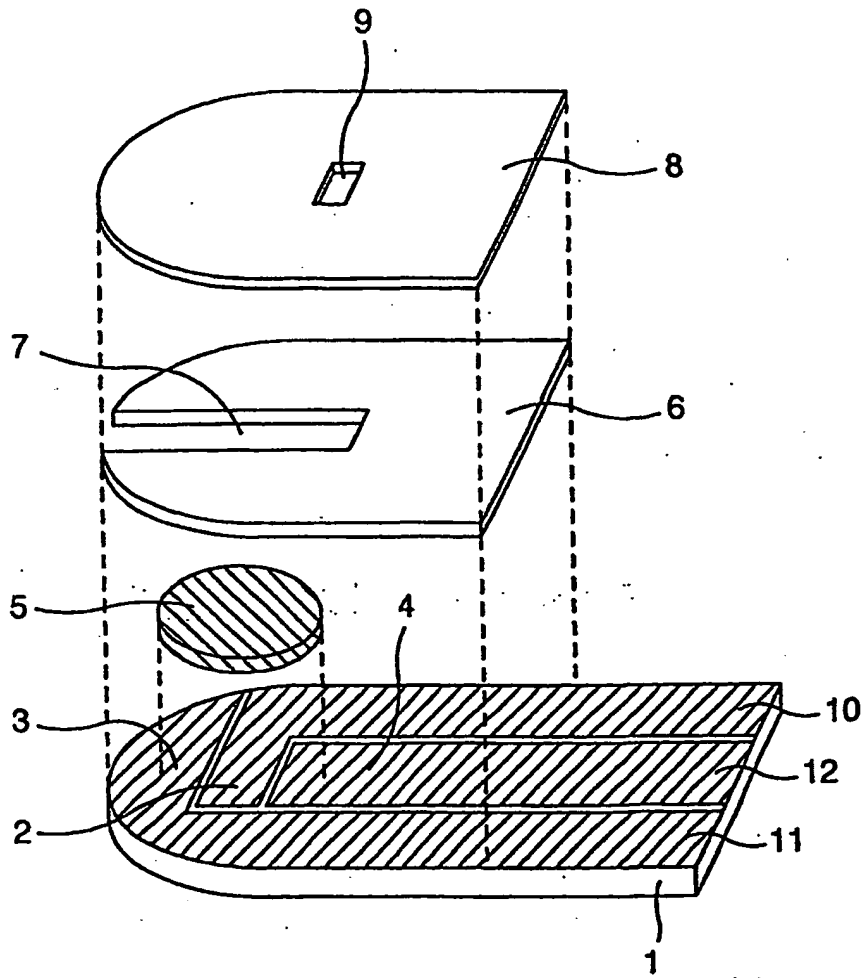

FIG. 4

(a)



(b)

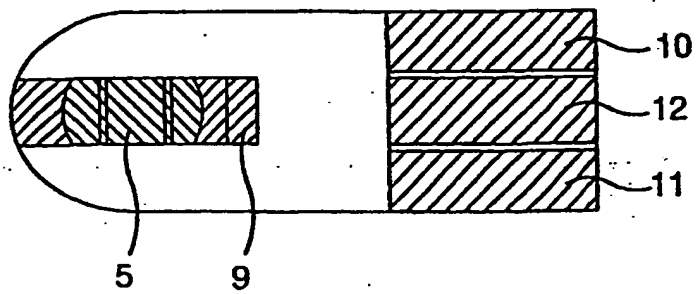

FIG. 5

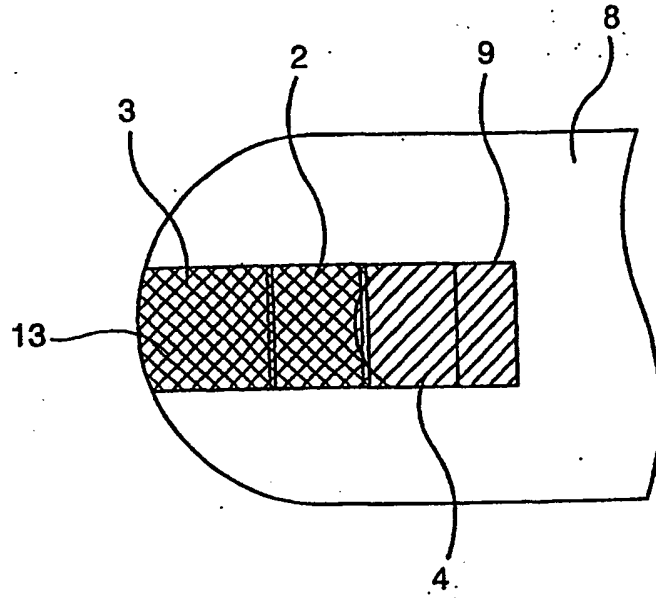

FIG. 6

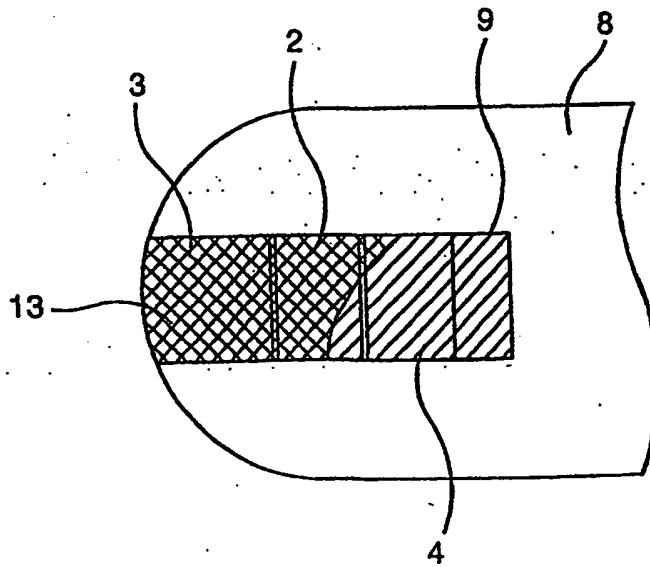
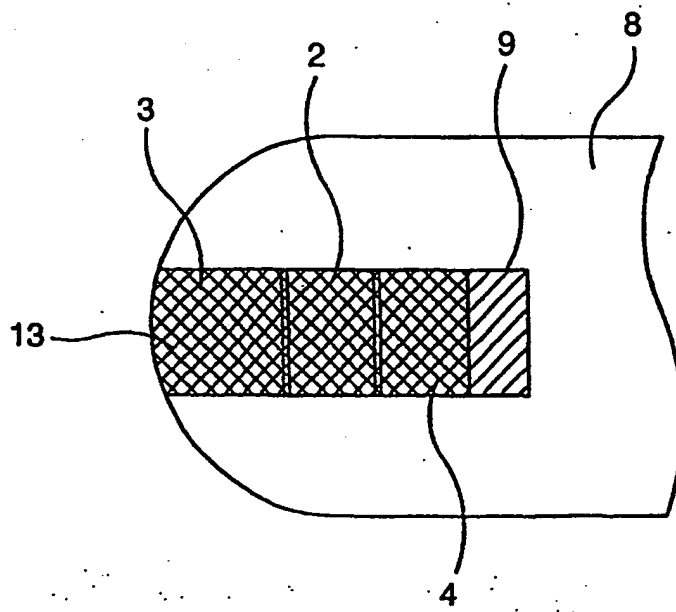

FIG. 7



List of reference numerals

- 1 First electrically insulated board
- 2 Measuring electrode
- 3 Counter electrode
- 4 Detecting electrode
- 5 Reagent layer
- 6 Spacer
- 7 Analyte feed passage
- 8 Second electrically insulated board (cover)
- 9 Air vent
- 10,11,12 Lead
- 13 Sample liquid
- 14, 15 Arc slit

INTERNATIONAL SEARCH REPORT

International application No.

PCT/JP02/03600

A. CLASSIFICATION OF SUBJECT MATTER Int.Cl. ⁷ G01N27/327		
According to International Patent Classification (IPC) or to both national classification and IPC		
B. FIELDS SEARCHED Minimum documentation searched (classification system followed by classification symbols) Int.Cl. ⁷ G01N27/327		
Documentation searched other than minimum documentation to the extent that such documents are included in the fields searched Jitsuyo Shinan Koho 1922-1996 Toroku Jitsuyo Shinan Koho 1994-2002 Kokai Jitsuyo Shinan Koho 1971-2002 Jitsuyo Shinan Toroku Koho 1996-2002		
Electronic data base consulted during the international search (name of data base and, where practicable, search terms used)		
C. DOCUMENTS CONSIDERED TO BE RELEVANT		
Category*	Citation of document, with indication, where appropriate, of the relevant passages	Relevant to claim No.
X	JP8-320304 A (Matsushita Electric Industrial Co., Ltd.) 03 December, 1996 (03.12.96), Full text; Figs. 1 to 2	1, 10
Y	Full text; Figs. 1 to 2 & EP 732406 A1 & CA 2153350 A & US 5650062 A1	6, 7, 8, 9
X	JP 4-357452 A (Matsushita Electric Industrial Co., Ltd., KDK Corp.), 10 December, 1992 (10.12.92), Full text; Fig. 5 & DE 69113923 A	1, 10
<input checked="" type="checkbox"/> Further documents are listed in the continuation of Box C. <input type="checkbox"/> See patent family annex.		
* Special categories of cited documents: "A" document defining the general state of the art which is not considered to be of particular relevance "E" earlier document but published on or after the international filing date "L" document which may throw doubts on priority claim(s) or which is cited to establish the publication date of another citation or other special reason (as specified) "O" document referring to an oral disclosure, use, exhibition or other means "P" document published prior to the international filing date but later than the priority date claimed "T" later document published after the international filing date or priority date and not in conflict with the application but cited to understand the principle or theory underlying the invention "X" document of particular relevance; the claimed invention cannot be considered novel or cannot be considered to involve an inventive step when the document is taken alone "Y" document of particular relevance; the claimed invention cannot be considered to involve an inventive step when the document is combined with one or more other such documents, such combination being obvious to a person skilled in the art "Z" document member of the same patent family		
Date of the actual completion of the international search 14 May, 2002 (14.05.02)		Date of mailing of the international search report 28 May, 2002 (28.05.02)
Name and mailing address of the ISA/ Japanese Patent Office		Authorized officer
Facsimile No.		Telephone No.

Form PCT/ISA/210 (second sheet) (July 1998)

INTERNATIONAL SEARCH REPORT

International application No.
PCT/JP02/03600

C (Continuation). DOCUMENTS CONSIDERED TO BE RELEVANT		
Category*	Citation of document, with indication, where appropriate, of the relevant passages	Relevant to claim No.
X Y	JP 6-109688 A (Matsushita Electric Industrial Co., Ltd.), 22 April, 1994 (22.04.94), Full text; Par. No. [0010]; Fig. 1 Full text; Fig. 1 (Family: none)	1-5,10 6,7,8,9
Y	JP 1-291153 A (Matsushita Electric Industrial Co., Ltd.), 22 November, 1989 (22.11.89), Page 2, lower right column, lines 3 to 13 & DE 68924026 C & WO 89/009397 A1 & EP 359831 A1 & US 5120420 A1	6,7
Y	JP 6-229970 A (Matsushita Electric Industrial Co., Ltd.), 19 August, 1994 (19.08.94), Par. No. [0017]; Fig. 4 (Family: none)	6,7
Y	JP 9-189675 A (Matsushita Electric Industrial Co., Ltd.), 22 July, 1997 (22.07.97), Full text; Figs. 1 to 3 & US 6004441 A1	8,9
Y	JP 3-75552 A (Omron Corp.), 29 March, 1991 (29.03.91), Full text; Figs. 1 to 2 (Family: none)	8
P,A	JP 2001-208715 A (Matsushita Electric Industrial Co., Ltd.), 03 August, 2001 (03.08.01), Full text; Figs. 1 to 7 (Family: none)	1-10
P,A	JP 2001-305093 A (Matsushita Electric Industrial Co., Ltd.), 31 October, 2001 (31.10.01), Full text; Figs. 1 to 3 (Family: none)	1-10
P,A	JP 2001-330581 A (Matsushita Electric Industrial Co., Ltd.), 30 November, 2001 (30.11.01), Full text; Figs. 1 to 3 (Family: none)	1-10
P,A	JP 2001-356108 A (Matsushita Electric Industrial Co., Ltd.), 26 December, 2001 (26.12.01), Full text; Figs. 1 to 7 (Family: none)	1-10

Form PCT/ISA/210 (continuation of second sheet) (July 1998)

INTERNATIONAL SEARCH REPORT

International application No.

PCT/JP02/03600

C (Continuation). DOCUMENTS CONSIDERED TO BE RELEVANT		
Category*	Citation of document, with indication, where appropriate, of the relevant passages	Relevant to claim No.
P, A	JP 2001-305096 A (Matsushita Electric Industrial Co., Ltd.), 31 October, 2001 (31.10.01), Full text; Figs. 1 to 7 (Family: none)	1-10
A	JP 2001-66279 A (Bayer Corp.), 16 March, 2001 (16.03.01), Full text; Figs. 1 to 2 (Family: none)	1-10
A	JP 2000-65778 A (Matsushita Electric Industrial Co., Ltd.), 03 March, 2000 (03.03.00), Full text; Figs. 1 to 3 & EP 984069 A2 & CN 1246614 A & US 6212417 B1	1-10
A	JP 9-43189 A (Matsushita Electric Industrial Co., Ltd.), 14 February, 1997 (14.02.97), Full text; Fig. 1 (Family: none)	1-10
A	JP 5-340915 A (Matsushita Electric Industrial Co., Ltd.), 24 December, 1993 (24.12.93), Full text; Figs. 1 to 4 & AU 5078593 A & DE 69328920 D & EP 601777 A1 & US 5347227 A1 & CN 1093209 A & ES 2148207 T & DE 69328920 T	1-10

Form PCT/ISA/210 (continuation of second sheet) (July 1998)

THIS PAGE BLANK (USPTO)